

DRAWING NO	MS51B-SF03		
PART NAME	Explosive Diagram		
PART NO	1000437003	REV	A
APPROVE	Taoyongchun	DATE	09/16/19

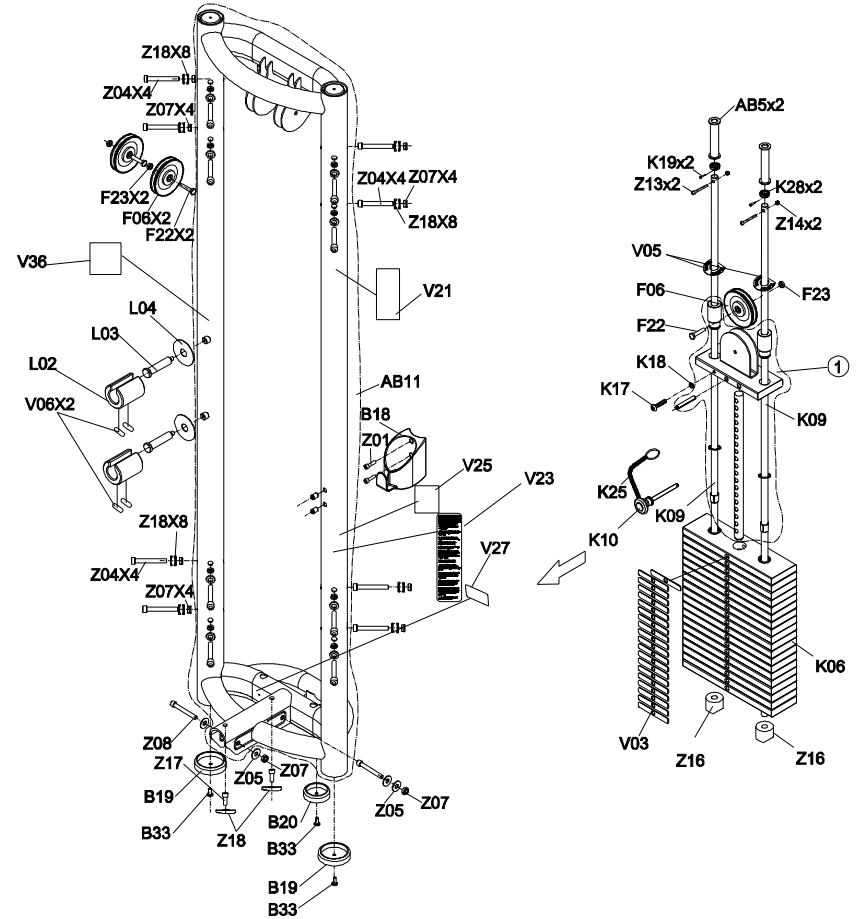
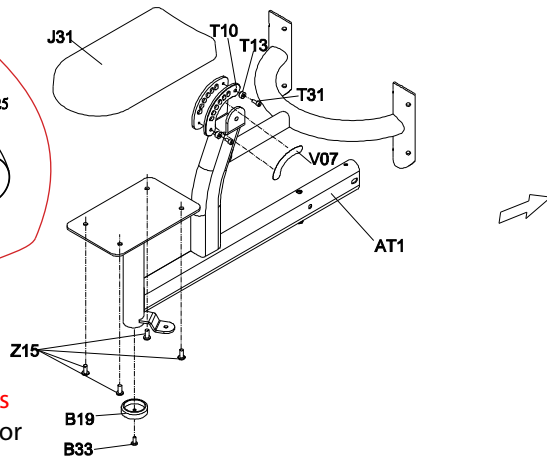
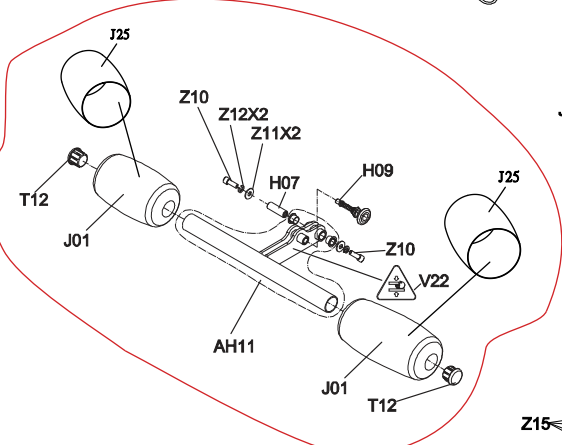
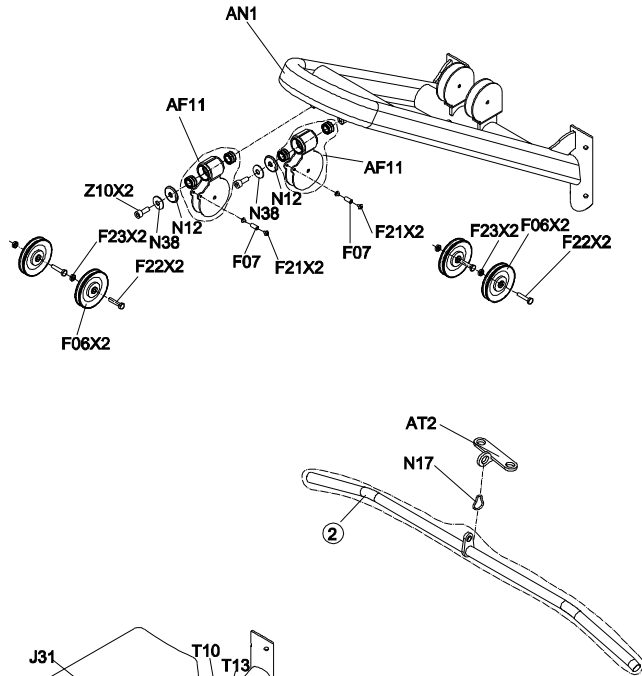
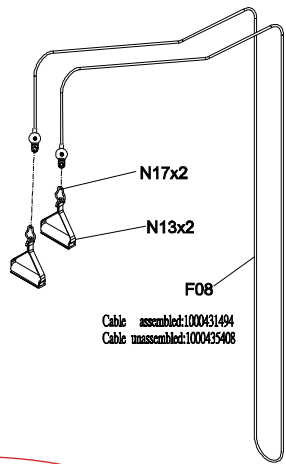

Units produced before July 2019 have the pads shown here. If unit was produced in July 2019 or after, or to upgrade an older unit to the new round pad design, [click here](#).

UNLESS OTHERWISE SPECIFIED TOLERANCES ARE:

LENGTH		ANGLE	
X.	±1.5	X.	±1°
X.X	±0.5	X.X	±0.5°
X.XX	±0.20	X.XX	±0.10°
X.XXX	±0.100		

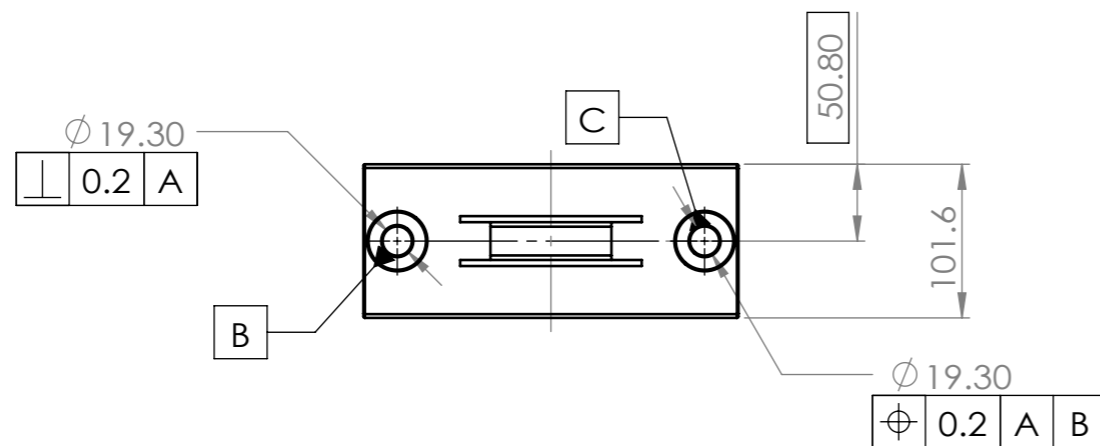
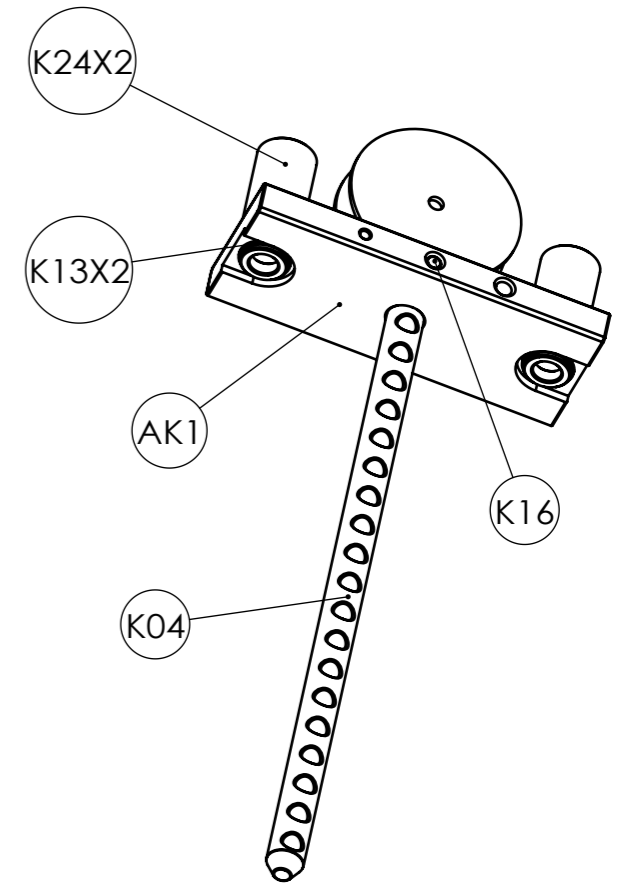
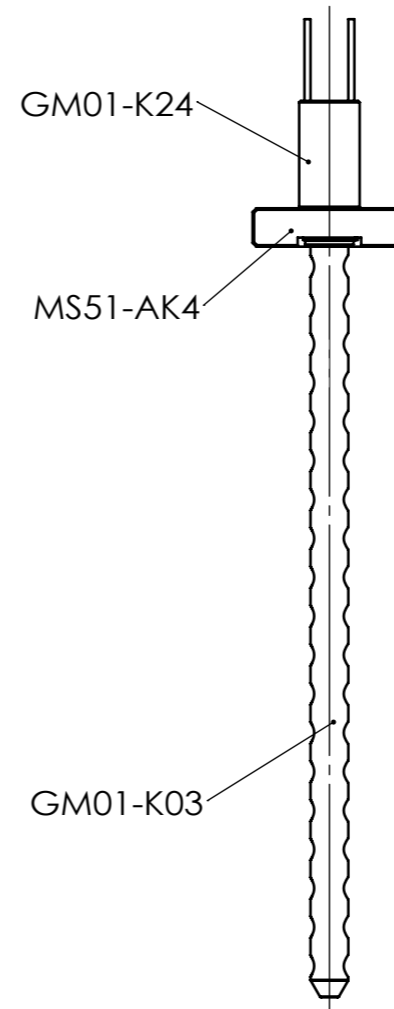
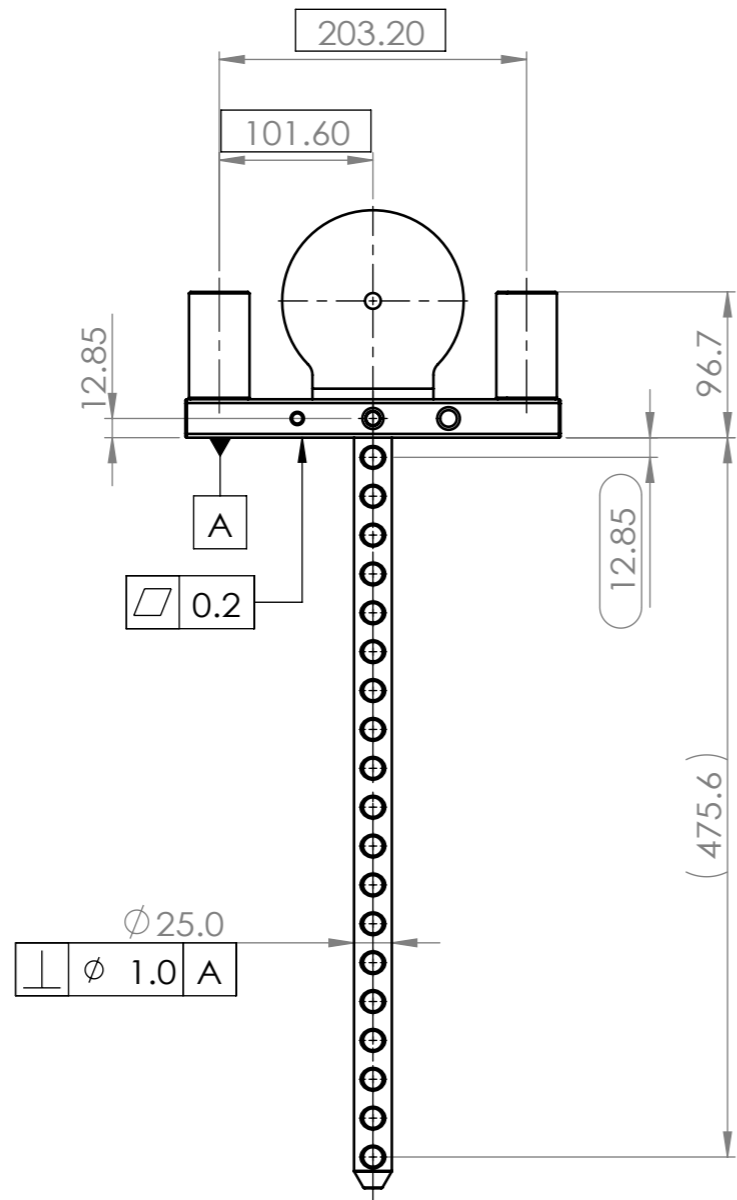

備註:

1. 所有尺寸為最終尺寸;
2. 此為外觀件, 須依喬山標準檢驗.

Notes:

1. All dimension is coated dimension;
2. It's a parts that could be seen by user, should be made in accordance with JIS Inspection Standard.

UNIT	mm	MODEL NO	LAT PULL	狀 態	P/D
單 位	mm	機 種	LAT PULL	狀 態	P/D
SCALE	1:10	DRAWING NO	MS51-AK10		
比 例	1:10	圖 號	MS51-AK10		
SHEET SIZE	A3	PART NAME(CH)	加工;上層選擇片組		
圖 紙 大 小	A3	零 件 名 稱 (中 文)	加工;上層選擇片組		
		PART NAME(EN)	EXTRAWORK;WEIGHT PLATE SET		
		零 件 名 稱 (英 文)	EXTRAWORK;WEIGHT PLATE SET		
		SAP PART NO	1000318313	REV	A
		SAP 料 號	1000318313	REV	A
A	13050199	RELEASED FOR PRODUCTION	SPENCER	061013	ARES 060613
LET	ECO NO	DESCRIPTION	APPROVER	DATE	DESIGN
項 目	設 變 單 號	修 改 內 容	審 核	日 期	日 期



喬山健康科技(台灣)有限公司
JOHNSON HEALTH TEC. (TAIWAN) CO.,LTD
喬山健康科技(上海)有限公司
JOHNSON HEALTH TEC. (SHANGHAI) CO.,LTD

DRAWING NO	PL08B-SF05		
PART NAME	Adjust set;Semi-Assy;		
PART NO	SEE CHART	REV	B
APPROVE	Taoyongchun	DATE	09/16/2019

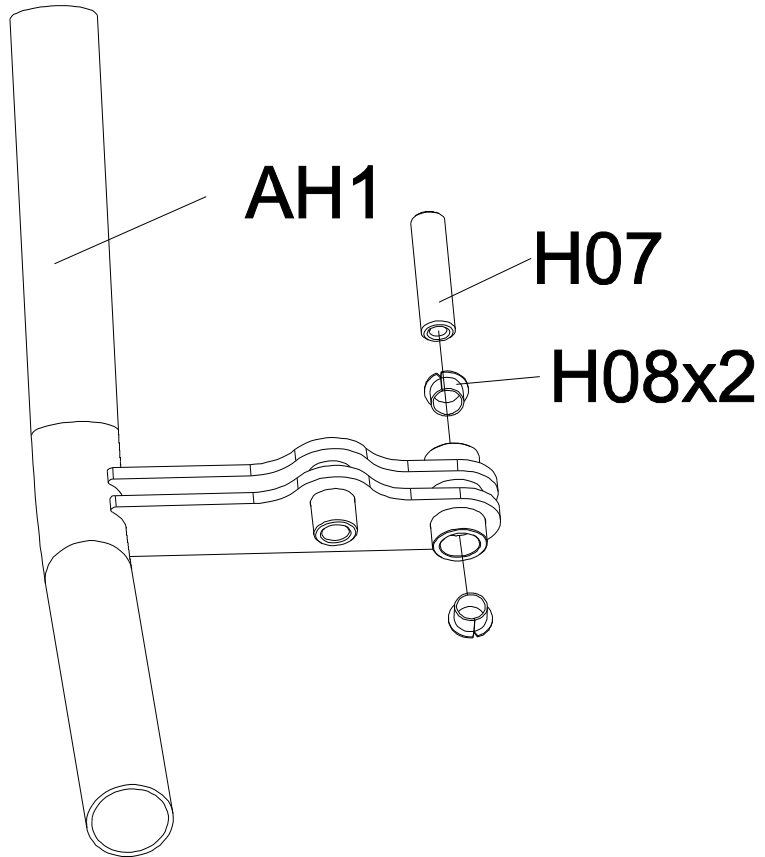

PART NO	Painting Color
1000360737	Iced Sliver
1000360739	Platinum
1000360740	Polarrized Titanium
1000360742	lace White
1000360738	Black Matte
1000360741	Black Glossy
1000440339	PF Yellow
1000439026	PF Purple
1000439028	O-PF Purple

DRAWING NO	MS51B-SF01		
PART NAME	Handle Set;Assembly		
PART NO	1000419004	REV	A
APPROVE	PAIGE	DATE	03.06.2018

